



Polskie Stowarzyszenie Gipsu



**Instytut Technologii Eksploatacji
– Państwowy Instytut Badawczy**

Piotr Rogalski

Krzysztof Wojewoda

Installation of wall lining systems 712[06].S1.03

Teacher's Guidebook



Publisher

**Instytut Technologii Eksploatacji – Państwowy Instytut Badawczy
Radom 2010**

Reviewers:

Halina Darecka, M.Sc.

Jolanta Skoczylas, M.Sc.

Editor: Ireneusz Woźniak, Ph.D., Eng.

Consultant: Krzysztof Baranowski, Secretary of the Polish Association of Plaster of Paris

Proof-reader:

This Handbook provides methodological guidance for the 712[06].S1.03 modular unit program “Installation of wall lining systems” being a part of the modular teaching program for the occupation of Bricklayer (712[06].).

Publisher

Instytut Technologii Eksploatacji – Państwowy Instytut Badawczy, Radom 2010

Table of contents

1. Introduction	3
2. Prerequisite skills	5
3. Learning objectives	6
4. Samples of lesson scenarios	7
5. Tasks	11
5.1. Wall lining systems	11
5.1.1. Tasks	11
5.2. Steps in the installation of wall lining systems	13
5.2.1. Tasks	13
5.3. Joint filling and finishing works	16
5.3.1. Tasks	16
6. Evaluation of student's achievements	18
7. Bibliography	35

1. INTRODUCTION

We are providing you with “Teacher’s Guidebook” “Installation of Wall Lining Systems”, which will help teachers in conducting lessons within the school training in the occupation of Bricklayer (712[06]).

The Guidebook contains:

- prerequisite skills,
- list of professional skills that a student acquires during the lessons,
- samples of lesson scenarios,
- recommended tasks which aim at teaching a student practical skills,
- list of literature that students can use in the process of education,

It is recommended that different teaching methods should be used in the process of training with particular focus on:

- demonstration with explanation,
- guiding text method,
- learning through projects,
- practical classes.

The forms in which students’ work is organised can vary, ranging from students’ independent work to team work.

In order to check students’ knowledge and skills, the teacher can use test tasks included in Chapter 6 and containing different types of tasks.

The said Chapter contains also:

- test plan in a tabular form,
- evaluation scale (points) for tasks and grading scheme,
- proposed grading standards,
- instructions for the teacher,
- instructions for a student,
- answer sheet,
- set of test tasks.

Diagram of modular units

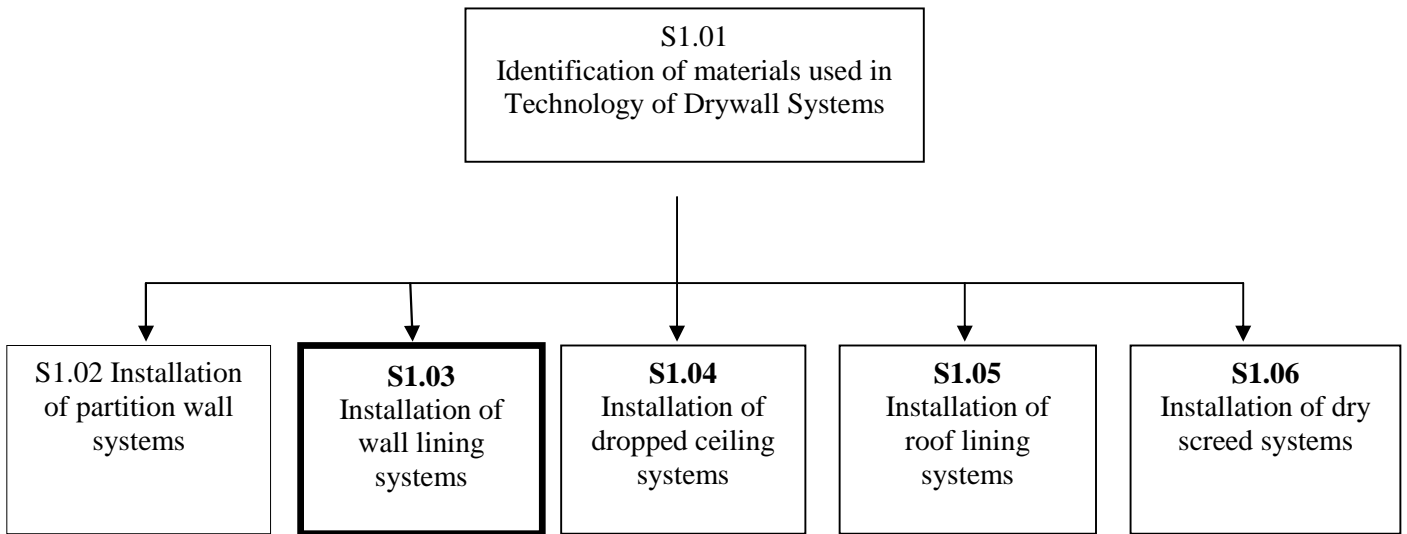

2. PREREQUISITE SKILLS

Before starting the modular unit program “Installation of wall lining systems”, a student should be able to:

- use technical building terminology,
- read and construe technical building drawings,
- use technical building documentation,
- organize the workplace in line with rules of ergonomics and safety,
- ensure the proper transportation of building materials,
- use different sources of information,
- identify materials used in technology of interior drywall systems,
- prepare gypsum mortar,
- select materials and equipment for assembly works,
- take basic measurements needed in construction works,
- build scaffolding for construction works.

3. LEARNING OBJECTIVES

Upon completion of the modular unit program, a students should be able to:

- prepare the workplace for installation of wall lining systems,
- prepare a place where materials for the installation of wall lining systems can be stored
- prepare the background for wall linings,
- select appropriate boards,
- prepare and cut to size the boards for the wall lining system,
- attach wall linings directly to masonry background,
- mark guidelines on the floor and the ceiling to establish the new wall plane,
- mark vertical guidelines on the background to establish the bonding positions,
- determine the places where brackets for fastening plasterboards should be placed,
- select and assemble steel profiles appropriate for the installation of wall linings,
- fit insulation material,
- attach the boards to the profiles,
- install wall linings with cavities in which service lines can be concealed,
- complete finish works such as filling, finishing external angles, board cleaning,
- apply the occupational health and safety rules, fire regulations as well as environmental law requirements

4. SAMPLES OF LESSON SCENARIOS

Lesson scenario 1

Person in charge:

Modular training program: Bricklayer 712[06]

Specialisation module: Technology of Interior Drywall Systems 712[06].S1.

Modular unit: Installation of wall lining systems 712[06].S1.03

Subject: Determination of the wall lining positioning.

General Objective: Using a way of determining the drywall lining positioning.

Upon completion of the training, a student is able to:

- determine the plane positioning of a wall on which a drywall is going to be installed,
- determine the plane of the drywall lining positioning,
- mark the positioning of a wall lining by means of gypsum dabs.

Teaching-learning methods:

- demonstration with instructions,

Forms of students' work organisation:

- individual work,
- group work.

Time: 300 minutes.

Teaching aids:

- sets of tasks developed by the teacher for each team of students,
- measuring instruments (plumbs, spirit levels, a string, a bricklayer's laser),
- trowel,
- gypsum adhesive,
- drawing instruments.

Lesson plan:

Task for a student:

The aim of the task is to determine the position of a drywall (plasterboard) lining.

PRELIMINARY STAGE

Activities related to the organisation and management of the lesson, giving the lesson subject, familiarising students with the method of demonstration with instructions.

PROPER STAGE

Phase 1:

1. Explaining the aim and subject of the demonstration.
2. Demonstration of establishing the drywall lining positioning.
3. Demonstration of more complicated activities while establishing the wall lining positioning.

Phase 2:

1. Selecting a group of students who will demonstrate establishing the wall lining positioning.
2. A selected group of students slowly performs establishing of the wall lining positioning.
3. A selected group of students performs establishing of the wall lining positioning at a normal pace.

Phase 3:

1. Divide all students into smaller groups (of 2-3 persons).
2. All students perform the activity of establishing the wall lining positioning.
3. Evaluation of the performance standards of all activities connected with establishing the wall lining positioning.

FINAL STAGE

Students and the teacher together indicate which stages of the task turned out to be most difficult for them. The teacher sums up the whole task and points out the new important skills which were developed in the course of the task completion as well as shortcomings which occurred.

Homework

In available sources find drawings or photographs depicting different wall lining structures. Bring the materials you have found and present them in the classroom.

The way to receive feedback from students after the classes have ended:

- anonymous evaluation sheets concerning the way of conducting the classes, difficulties encountered during the task, acquired skills and teaching materials used,
- analysis of students' activity during the classes.

Lesson scenario 2

Person in charge:

Modular training program: Bricklayer 712[06]

Specialisation module: Technology of Interior Drywall Systems 712[06].S1.

Modular unit: Installation of wall lining systems 712[06].S1.03

Subject: Adhesive bonding of plasterboards to a masonry wall.

General objective: Developing a skill of adhesive bonding of plasterboards to masonry walls.

Upon completion of the training, a student is able to:

- select materials and equipment for plasterboard bonding,
- organize the workplace for adhesive bonding in line with safety rules,
- perform adhesive bonding of plasterboards to masonry walls,
- assess the task completed.

Teaching-learning methods:

- practical tasks.

Forms of students' work organisation:

- team work (groups of two).

Time: 220 minutes.

Teaching aids:

- masonry wall of appropriate dimensions,
- technical documentation,
- plasterboards,
- system-included gypsum adhesive,
- basic measuring equipment,
- tools for gypsum adhesive application,
- industrial safety rules,
- reference material from Chapter 7 of Teacher's Guidebook.

Lesson plan:

Task for a student:

The aim of the task is to attach plasterboards to a masonry wall.

Phase 1:

1. Organizational matters.
2. Referring to the lesson subject, discussing lesson objectives.
3. Theoretical information and description of activities which must be performed to attach plasterboards with adhesive.
4. Industrial safety rules training
5. Organizing the workplace for task performance.
6. Demonstration by the teacher of how to attach plasterboards to a masonry wall with the use of adhesive. Demonstration is carried out at a normal pace.

Phase 2:

1. The teacher demonstrates how to attach plasterboards with adhesive to a masonry wall . Demonstration is performed at a slower pace with a simultaneous explanation of relevant activities occurring when a plasterboard is being attached with adhesive.
2. The teacher demonstrates how to bond a plasterboard with adhesive to a masonry wall. He performs the demonstration at a normal pace.

Phase 3:

In pairs, students:

- take tools from a storeroom to perform the task,
- establish the wall lining positioning,
- prepare a plasterboard for installation,
- apply adhesive to the wall,
- attach plasterboards to adhesive “dabs” on the wall,
- attach the second plasterboard next to the first one,
- check correctness of plasterboard fixing using a spirit level to this purpose,
- fix angle strengthening profiles
- perform joint filling.

Finishing the lesson:

- 1) Each student indicates his strengths and weaknesses.
- 2) The teacher analyzes students’ works and concludes whether the works were performed correctly.
- 3) Students present their work following the sequence of the works performed.
- 4) The group together with the teacher assess their work.

Homework

In available sources find drawings or photographs depicting different finishing techniques of partition walls and wall linings made of plasterboards. Bring the materials you have found and present them in the classroom.

The way to receive feedback from students after the classes have ended:

- anonymous evaluation sheets concerning the way of conducting the classes and acquired skills,
- analysis of students’ activity during the classes.

5. TASKS

5.1. Wall lining systems

5.1.1. Tasks

Task 1

Identify types of wall lining systems provided by the teacher in the form of drawings or models.

Tips for task performance

Before starting the task, the teacher should discuss its scope and performance technique.

The way to do the task:

A student should:

- 1) get familiar with types of wall linings (reference material from Chapter 4.1.1),
- 2) get familiar with materials provided by the teacher,
- 3) identify particular types of wall linings,
- 4) present the completed task,
- 5) assess correctness of the task completed.

Recommended teaching-learning methods:

- the guiding-text method

Teaching aids:

- reference material from Chapter 4.1 of Student's Handbook,
- drawing instruments,
- drawings or models of wall lining systems.

Task 2

On the basis of the documentation provided by the teacher and the places indicated for the wall lining installation, propose an appropriate type of wall lining.

Tips for task performance

Before starting the task, the teacher should discuss its scope and performance technique.

The way to do the task:

A student should:

- 1) get familiar with types of wall lining systems (reference material from Chapter 4.1.1),
- 2) get familiar with materials provided by the teacher,
- 3) get familiar with the substrate to which the wall lining is to be attached,
- 4) organize the workplace for task performance,
- 5) select an appropriate type of wall lining,
- 6) present the completed task,
- 7) assess correctness and aesthetics of the task completed.

Recommended teaching-learning methods:

- project method, a guiding-text method

Teaching aids:

- technical documentation,
- drawing instruments
- reference material from Chapter 4.1 of Student's Handbook,

Task 3

Group the teacher provided cards with names of different materials by their application in wall lining systems.

Tips for task performance

Before starting the task, the teacher should discuss its scope and performance technique.

The way to do the task:

A student should:

- 1) get familiar with types of wall linings (reference material from Chapter 4.1.1),
- 2) get familiar with the wall lining system structure (reference material from Chapter 4.1.1),
- 3) organize the workplace for task performance,
- 4) group the cards by names of the materials and match to the type of wall linings,
- 5) present the completed task,
- 6) assess correctness and aesthetics of the task completed.

Recommended teaching-learning methods:

- the guiding-text method, project method.

Teaching aids:

- cards with names of materials used in wall lining systems,
- reference material from Chapter 4.1 of Student's Handbook,

5.2. Steps in the installation of wall lining systems

5.2.1. Tasks

Task 1

On the basis of the technical documentation of the room indicated by the teacher, determine the plasterboard positioning.

Tips for task performance

Before starting the task, the teacher should discuss its scope and performance technique.

The way to do the task:

A student should:

- 1) get familiar with plasterboard structure (reference material from Chapter 4.2),
- 2) get familiar with the documentation of the place where plasterboard is to be applied,
- 3) organize the workplace for task performance,
- 4) prepare materials and equipment for the plasterboard positioning,
- 5) determine the plasterboard positioning
- 6) present the completed task,
- 7) assess correctness and aesthetics of the task completed.

Recommended teaching-learning methods:

- demonstration with explanation, demonstration with instructions, problem-focused tasks.

Teaching aids:

- technical documentation of the room,
- materials for plasterboard installation,
- measuring instruments,
- tools and equipment for plasterboard installation,
- drawing instruments
- reference material from Chapter 4 of Student's Handbook,

Task 2

On a plasterboard determine the places of gypsum adhesive application in line with the rules of plasterboard adhesive bonding.

Tips for task performance

Before starting the task, the teacher should discuss its scope and performance technique.

The way to do the task:

A student should:

- 1) get familiar with the plasterboard structure (reference material from Chapter 4.1.1),
- 2) get familiar with the rules of determining the gypsum dabs positioning and gypsum adhesive application to plasterboards,
- 3) organize the workplace for task performance,
- 4) mark (e.g. with a piece of chalk) the places of gypsum adhesive application to plasterboards,
- 5) present the completed task,
- 6) assess correctness and aesthetics of the task completed.

Recommended teaching-learning methods:
- the guiding-text method, problem-focused tasks.

Teaching aids:
- plasterboard,
- drawing instruments,
- reference material from Chapter 4.1 of Student's Handbook,

Task 3

Attach two plasterboards to the wall indicated by the teacher.

Tips for task performance
Before starting the task, the teacher should discuss its scope and performance technique.

The way to do the task:

A student should:

- 1) get familiar with plasterboard installation (reference material from Chapter 4.2)
- 2) get familiar with the place where plasterboards are to be attached,
- 3) organize the workplace for task performance,
- 4) prepare plasterboards,
- 5) select materials,
- 6) apply gypsum adhesive to plasterboards,
- 6) present the completed task,
- 7) assess correctness and aesthetics of the task completed.

Recommended teaching-learning methods:
- demonstration with instructions, demonstration with explanation, problem-focused tasks.

Teaching aids:
- plasterboards,
- tools and equipment for plasterboard attachment,
- gypsum adhesive,
- reference material from Chapter 4 of Student's Handbook,

Task 4

Determine the wall lining positioning on CD60 profiles and location of ES brackets needed for their fixing.

Tips for task performance
Before starting the task, the teacher should discuss its scope and performance technique.

The way to do the task:

A student should:

- 1) get familiar with the installation of a wall lining on CD60 profiles (reference material from Chapter 4.2),
- 2) get familiar with the place where a wall lining is to be installed,
- 3) organize the workplace for task performance,
- 4) prepare tools and equipment for the wall lining positioning,
- 5) determine the wall lining positioning in places where service lines are installed,
- 6) fix profiles and brackets,

- 7) attach plasterboards,
- 8) present the completed task,
- 9) assess correctness and aesthetics of the task completed.

Recommended teaching-learning methods:

- demonstration with explanation, demonstration with instructions

Teaching aids:

- plasterboards,
- steel profiles,
- tools and equipment for the assembly,
- reference material from Chapter 4 of Student's Handbook.

Task 5

- Install a fragment of a wall lining prepared for the installation of water and sewerage piping (e.g. shaft lining).

Tips for task performance

Before starting the task, the teacher should discuss its scope and performance technique.

The way to do the task:

A student should:

- 1) get familiar with installation of wall linings on CD60 profiles (reference material from Chapter 4.2),
- 2) get familiar with the place where a wall lining is to be installed,
- 3) organize the workplace for task performance,
- 4) prepare tools and equipment for the wall lining positioning,
- 5) determine the wall lining positioning in places where service lines are to be installed,
- 6) fix profiles and brackets,
- 7) attach plasterboards,
- 8) present the completed task,
- 9) assess correctness and aesthetics of the task completed.

Recommended teaching-learning methods:

- demonstration with explanation, demonstration with instructions

Teaching aids:

- plasterboards,
- steel profiles,
- tools and equipment for the assembly,
- reference material from Chapter 4 of Student's Handbook.

5.3. Joint filling and finishing works

5.3.1. Tasks

Task 1

Perform joint filling on a fragment of a plasterboard wall lining indicated by the teacher.

Tips for task performance

Before starting the task, the teacher should discuss its scope and performance technique.

The way to do the task:

A student should:

- 1) get familiar with the wall lining structure where joint filling is to be performed,
- 2) select the joint filling quality level,
- 3) organize the workplace for task performance,
- 4) select materials and equipment for aligning the board so that it is plumb,
- 5) perform joint filling on the indicated part of a wall lining,
- 6) present the completed task,
- 7) assess correctness and aesthetics of the task completed.

Recommended teaching-learning methods:

- demonstration with explanation, demonstration with instructions, subject-focused tasks

Teaching aids:

- wall lining fragments made of plasterboards,
- joint filling material,
- tools for joint filling
- reference material from Chapter 4 of Student's Handbook.

Task 2

Finish the internal angle between the ceiling and the wall with a wall lining attached to it.

Tips for task performance

Before starting the task, the teacher should discuss its scope and performance technique.

The way to do the task:

A student should:

- 1) get familiar with the place in which an internal angle is to be finished,
- 2) identify the method in which the angle is to be finished,
- 3) select the joint filling quality level,
- 4) organize the workplace for task performance,
- 5) select materials and equipment for aligning the board so that it is plumb,
- 6) select materials and equipment for the internal angle finishing,
- 7) finish the angle indicated,
- 8) present the completed task,
- 9) assess correctness and aesthetics of the task completed.

Recommended teaching-learning methods:

- demonstration with explanation, demonstration with instructions, subject-focused tasks

Teaching aids:

- a fragment of the ceiling and a plasterboard wall lining,
- materials for joint filling,
- tools for joint filling,
- materials for finishing the angle,
- reference material from Chapter 4 of Student's Handbook.

Task 3

Finish the external angle of the walls with a plasterboard wall lining attached to them.

Tips for task performance

Before starting the task, the teacher should discuss its scope and performance technique.

The way to do the task:

A student should:

- 1) get familiar with the place where the external angle is to be finished,
- 2) specify the method of finishing the angle,
- 3) select the joint filling quality level,
- 4) organize the workplace for task performance,
- 5) select materials for finishing the external angle,
- 6) select materials and equipment for aligning the board so that it is plumb,
- 7) finish the angle indicated,
- 8) present the completed task,
- 9) assess correctness and aesthetics of the task completed.

Recommended teaching-learning methods:

- demonstration with explanation, demonstration with instructions, subject-focused tasks.

Teaching aids:

- a fragment of a wall with a plasterboard wall lining attached to it,
- joint filling materials,
- materials for finishing the external angle,
- tools for joint filling,
- materials for finishing the angle,
- reference material from Chapter 4 of Student's Handbook.

6. EVALUATION OF STUDENTS' ACHIEVEMENTS

Samples of testing and assessment tools

TEST 1

A two-level test for the modular unit "Installation of wall lining systems".

The Test consists of 20 tasks of two difficulty levels:

- tasks 1, 2, 3, 4, 5, 6, 7, 8, 9, 10, 11, 12, 13, 14, 19 – represent a basic level,
- tasks 15, 16, 17, 18, 20 – represent an above-basic level.

Points awarded for task completion: 0; 0.5 or 1 point

For each correct answer a student scores 1 point. A wrong or no answer score 0 points. In open tasks a student scores 0.5 point when he answers correctly at least 50% of the task.

The following grading standards are proposed – a student will be awarded the following school grades:

- poor – if at least 7 tasks at the basic level have been done satisfactorily,
- satisfactory – if at least 10 tasks at the basic level have been done satisfactorily,
- good – for satisfactory completion of 14 tasks including at least 3 at the level above the basic one
- very good – for completion of 16 tasks including at least 4 from the above-basic level.

Test plan with an answer key

(Translator's remark: P = basic level; PP = the above-basic level)

Nr zadania	Operational task (assessment of student's achievements)	Kategoria celu	Poziom wymagań	Correct answer
1.	Identify basic properties of a wall lining system	A	P	-rigidity -strength -acoustic insulation -fire resistance
2.	Identify major elements of wall lining systems	A	P	-plasterboards, -steel profiles -mineral wool insulation - joint filling compound
3.	Identify the way of fixing plasterboards in drywall systems	B	P	c
4.	Identify the role of gypsum dabs in drywall system installation.	B	P	b
5.	Identify the length of adhesive bonded plasterboards in the drywall system installation	B	P	c

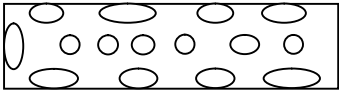
6.	Specify the height of rooms in which drywall systems can be used.	B	P	b
7.	Identify the place in which one can start fixing plasterboards in drywall systems depending on the room height	C	P	a) from the wall edge b) from the wall centre
8.	Identify the place where CD60 profiles must be fixed.	B	P	c
9.	Identify spacing between ES brackets for fixing CD60 profiles	B	P	a, c
10.	Identify profiles on which a pre-wall can be installed	B	P	c
11.	Identify for which wall lining systems one must determine the wall lining positioning	B	P	b, c
12.	On plasterboards mark the places where gypsum adhesive is to be applied	C	P	
13.	Determine the line of the wall lining positioning	B	P	c
14.	Identify elements of a wall lining structure on CD60 profiles.	B	P	a) 2-sealing tape b) 4-CD 60 profiles c) 5-UW profiles d) 6-ES brackets
15.	Identify types of materials used in installation of wall linings on outside walls	C	PP	vapour-insulation foil
16.	Determine the length of overlaps when joining CW (C) profiles.	B	PP	a) 50 cm, b) 75 cm, c) 100 cm.
17.	Determine a pre-wall height depending on the type of the profiles used.	C	PP	a) 3 m, b) 4 m, c) 5 m.
18.	Determine the length of a profile used for a pre-wall assembly in relation to the room	B	PP	b
19.	Identify the sequence of activities when plasterboards are cut	B	P	a
20.	Identify basic dimensional tolerances for the positioning of planes and edges which will be assessed during the acceptance of the completed works	B	PP	- divergence of a surface from the plane, i.e. is there any corrugation of the wall lining surface - divergence of the plane edge from the straight line, i.e. are there deviations vertically or horizontally from the place where two planes intersect, e.g. internal angles, or external angles of wall linings, - deviation of a plane and the edge from the vertical direction,

				- deviation of intersecting planes from the angle specified in technical documentation
--	--	--	--	--

Testing procedure

Instructions for the teacher

1. Together with your students establish a test-date at least a week in advance.
2. Discuss with students the aim of testing and assessment.
3. Familiarize students with types of tasks included in the test and with the rules of awarding points.
4. Conduct a mock test in which students will be asked to provide answers to the task types as the ones included in a real test.
5. Discuss with students the way in which answers shall be given (answer sheet).
6. Ensure conditions for students independent work.
7. Distribute sets of test tasks and answer sheets to students, inform them about the time limit for doing the test.
8. Create proper atmosphere during the whole test (relieve tension, encourage for checking one's potential).
9. A few minutes before the end of the test, remind students of the time left for the test completion.
10. Collect answer sheets and test sheets.
11. Check the results and enter them into a report sheet.
12. Analyze the results obtained and choose these tasks which posed most difficulty to students.
13. Establish the reasons why students had problems to acquire the knowledge and skills.
14. Work out conclusions for further work in order to avoid teaching failures – unsatisfactory results of the test conducted.

Instruction for students

1. Read the instruction carefully.
2. Sign the answer sheet with your name and surname.
3. Get familiar with test tasks.
4. The test consists of 20 tasks of different difficulty levels. It includes tasks of the following types: open, gap-fill, multiple-choice and True/False.
5. Give your answers on the enclosed answer sheet only. Put a cross (X) in the appropriate column or write the correct answer. If you make a mistake, put a circle around the incorrect answer and then put a cross (X) next to the correct answer.
6. The test consists of 2 parts containing tasks of different difficulty levels: tasks 1, 2, 3, 4, 5, 6, 7, 8, 9, 10, 11, 12, 13, 14, 19 – represent the basic level, whereas tasks: 15, 16, 17, 18 and 20 – represent the above-basic level.
7. Work on your own because only then you will get satisfaction of completing the task.
8. When you find answering a question difficult, leave it for a later time and return to it when you have time.
9. You have 90 minutes to complete the test.

Good luck!

Resources for a student:

- instructions,
- a set of test tasks,
- an answer sheet.

A SET of TEST TASKS

1. Identify the basic elements of the wall lining systems :
 - a)
 - b)
 - c)
 - d)

2. Identify the main wall lining systems.
 - a)
 - b)
 - c)

3. Plasterboards in drywall systems are fixed by means of:
 - a) adhesive bonding and mechanical fixing,
 - b) only mechanical fixing,
 - c) adhesive bonding
 - d) depending on the type of their structure.

4. What is the role of gypsum dabs in drywall systems?
 - a) they smooth out the wall to which plasterboards are attached.
 - b) mark the plane of the plasterboard positioning.
 - c) allow to use additional wall filling,
 - d) reduce adhesive consumption.

5. How long should adhesive bonded plasterboards in drywall systems be?
 - a) shorter by ca. 3 cm than the room height,
 - b) of the length which allows them to be well adjusted to the room height,
 - c) lower by 1.5 cm than the room height,
 - d) equal the room height.

6. The maximum permitted height of rooms in which plasterboard installation is performed is:
 - a) 2 m.
 - b) 3 m.
 - c) between 3 and 4 m.
 - d) 2.5 m.

7. Adhesive bonding of plasterboards starts from:
 - a)- when the wall is less than 6 m in length,
 - b) - when the wall is more than 6 m in length.

8. CD60 profiles are placed vertically and are fixed to:
- a) the floor and the ceiling by means of appropriate brackets.
 - b) the structural wall by means of appropriate brackets.
 - c) UD 30 wall profiles fixed to the floor and the ceiling.
 - d) UD30 wall profiles placed all over the wall.
9. The interval between the ES brackets for fixing CD60 profiles should be:
- a) maximum 125 cm vertically.
 - b) at least 125 cm vertically,
 - c) maximum 60 cm horizontally,
 - d) at least 60 cm horizontally.
10. Pre-walls are mounted on the following profiles:
- a) CD.
 - b) UW(U).
 - c) CW(C).
 - d) UA.
11. Which wall lining systems require marking a line indicating the wall lining positioning?
- a) plasterboards.
 - b) wall linings on CD60 profiles,
 - c) pre-walls.
12. On this plasterboard projection, mark the places of applying gypsum adhesive which is to bond the board to the wall.



13. The line marking the wall lining positioning on the floor should be the one:
- a) marking the position of the wall lining surface.
 - b) to which the centre of UW profiles is applied.
 - c) to which the external edge of UW profiles is applied.
 - d) to which the internal edge of UW profiles is applied.

14. Identify the elements of the wall lining structure on CD60 profiles:

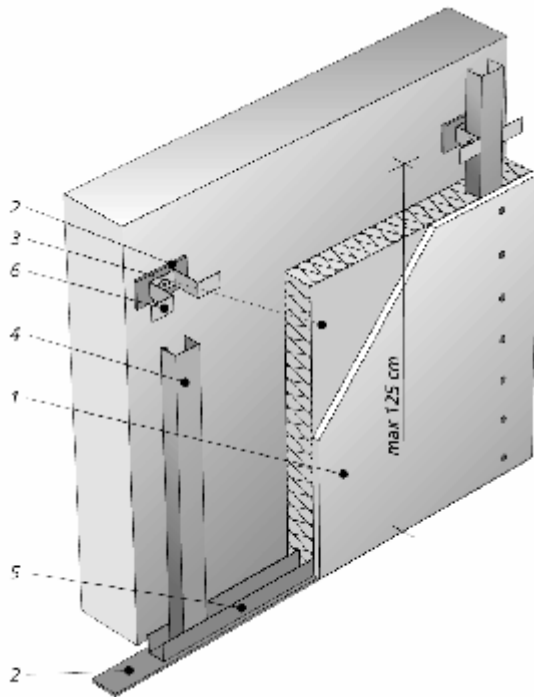

- a) 2 -
- b) 4 -
- c) 5 -
- d) 6 -

15. When installing a wall lining on the outside wall, apart from mineral wool, you must use:

.....

16. When you join profiles, the length of an overlap depends on their length and it is:

- a) for CW (C) 50 profiles -
- b) for CW (C) 75 profiles -
- c) for CW (C) 100 profiles -

17. The height of a pre-wall that can be accomplished with the use of the profiles indicated below is:

- a) for CW (C) 50, UW (U) 50 profiles -
- b) for CW (C) 75, UW (U) 75 profiles -
- c) for CW (C) 100, UW (U) 100 profiles -

18. The length of CW (C) profiles in a pre-wall structure should:
- a) equal the room height,
 - b) be less by ca. 1 cm than the room height,
 - c) be less by the CU profile thickness,
 - d) be less by ca. 2 cm than the room height.
19. Plasterboards are fixed to profiles which are:
- a) only vertical,
 - b) only horizontal,
 - c) vertical and horizontal,
 - d) vertical, but at bigger heights – also horizontal.
20. Identify the basic dimensional tolerances in the positioning of completed planes and edges, which will be assessed during the acceptance procedure of construction works:
- a)
 - b)
 - c)
 - d)
 - e)

ANSWER SHEET

Name and surname

Installation of wall lining systems

Mark the correct answer, write in a missing phrase or an answer.

Question number	Answers				Points scored
1	a	b	c	d	
2	a		b	c	
3	a	b	c	d	
4	a	b	c	d	
5	a	b	c	d	
6	a	b	c	d	
7	a		b		
8	a	b	c	d	
9	a	b	c	d	
10	a	b	c	d	
11	a	b	c		
12					
13	a	b	c	d	

14	a	b	c	d	
15					
16	a	b	c		
17	a	b	c		
18	a	b	c	d	
19	a	b	c	d	
20	a	b	c	d	e
Total					

TEST 2

A two-level test for the modular unit “Installation of wall lining systems.”

The Test consists of 20 tasks of two difficulty levels:

- tasks 1, 2, 3, 4, 5, 6, 7, 8, 10, 11, 12, 13, 14, 16, 17, 18 – represent the basic level,
- tasks 9, 15, 19, 20 – represent the above-basic level.

Points awarded for task completion: 0; 0.5 or 1 point

For each correct answer a student scores 1 point. A wrong or no answer score 0 points. In open tasks a student scores 0.5 point when he answers correctly at least 50% of the task.

The following grading standards are proposed – a student will be awarded the following school grades:

- poor – if at least 7 tasks at the basic level have been done satisfactorily,
- satisfactory – if at least 10 tasks at the basic level have been done satisfactorily,
- good – for satisfactory completion of 14 tasks including at least 3 at the level above the basic one
- very good – for completion of 16 tasks including at least 4 from the above-basic level.

Test plan with an answer key

(Translator’s remark: P = basic level; PP = the above-basic level)

Nr zadania	Operational task (assessment of student’s achievements)	Kategoria celu	Poziom wymagani	Correct answer
1.	Explain the term ”drywall system”	B	P	Paper-based plasterboards attached to a substrate
2.	Specify conditions which a substrate for plasterboards must meet.	B	P	Dry, not greasy, with no coats of lime or oil paints.
3.	Identify the role of gypsum dabs in drywall systems.	B	P	c
4.	Specify the way in which gypsum adhesive is applied to a plasterboard prior to its fixing.	B	P	d
5.	Identify the place from which one starts fixing plasterboards with adhesive depending on the wall length.	B	P	a
6.	Identify the cases in which it is justified to use wall linings on CD60 profiles	C	P	- the wall height exceeds 300 cm, - adhesive bonding to wall surfaces is not economically justified - in the case one expects improved acoustic and fire-resistance of the wall

7.	Identify the way of CD 60 profile positioning in the wall lining systems.	B	P	c
8.	Identify profiles used for a pre-wall installation	B	P	CW (C), UW
9.	Identify the length of overlaps in profiles depending on the pre-wall height.	B	PP	a) 0.5 m, b) 0.75 m, c) 1 m.
10.	Identify the place of marking a line of the wall line positioning on CD 60 profiles	B	P	c
11.	Identify the way of drawing a line indicating the pre-wall positioning.	B	P	d
12.	Identify the sequence of works in the wall lining assembly.	B	P	b
13.	Decide whether profiles CD60 and UD30 are connected in wall lining systems?	B	P	b
14.	Identify which profiles are used for the pre-wall installation?	B	P	c
15.	Specify when the vapour-insulation foil is used in the wall lining systems installation.	C	PP	d
16.	Identify profiles to which a plasterboard is fixed with screws.	B	P	a
17.	Identify the way in which plasterboards are positioned in the course of the wall lining installation.	B	P	b
18.	Identify the way in which mud is spread at first mudding.	B	P	b
19.	Identify the mudding quality level when ceramic tiles are to be applied to a wall lining.	B	PP	QL 1
20.	Specify the purpose for which primer is used	C	PP	To make absorption of plasterboards and mud uniform.

Testing procedure

Instructions for the teacher

1. Together with your students establish a test-date at least a week in advance.
2. Discuss with students the aim of testing and assessment.
3. Familiarize students with types of tasks included in the test and with the rules of awarding points.
4. Conduct a mock test in which students will be asked to provide answers to the task types as the ones included in a real test.
5. Discuss with students the way in which answers shall be given (answer sheet).
6. Ensure conditions for students independent work.
7. Distribute sets of test tasks and answer sheets to students, inform them about the time limit for doing the test.
8. Create proper atmosphere during the whole test (relieve tension, encourage for checking one's potential).
9. A few minutes before the end of the test, remind students of the time left for the test completion.
10. Collect answer sheets and test sheets.
11. Check the results and enter them into a report sheet.
12. Analyze the results obtained and choose these tasks which posed most difficulty to students.
13. Establish the reasons why students had problems to acquire the knowledge and skills.
14. Work out conclusions for further work in order to avoid teaching failures – unsatisfactory results of the test conducted.

Instructions for students

1. Read the instruction carefully.
2. Sign the answer sheet with your name and surname.
3. Get familiar with test tasks.
4. The test consists of 20 tasks of different difficulty levels. It includes tasks of the following types: open, gap-fill, multiple-choice and True/False.
5. Give your answers on the enclosed answer sheet only. Put a cross (X) in the appropriate column or write the correct answer. If you make a mistake, put a circle around the incorrect answer and then put a cross (X) next to the correct answer.
6. The test consists of 2 parts containing tasks of different difficulty levels: tasks 1, 2, 3, 4, 5, 6, 7, 8, 10, 11, 12, 13, 14, 16, 17 and 18 – represent the basic level, whereas tasks: 9, 15, 19, 20 – represent the above-basic level.
7. Work on your own because only then you will get satisfaction of completing the task.
8. When you find answering a question difficult, leave it for a later time and return to it when you have time.
9. You have 90 minutes to complete the test.

Good luck !

Resources for a student:

- instructions,
- set of test tasks,
- answer sheet.

A SET of TEST TASKS

1. What does the term “drywall system” mean?
.....
2. What conditions must a substrate for plasterboards meet?
.....
3. The role of gypsum dabs in drywall systems is as follows:
 - a) smoothing out the wall to which a plasterboard is applied,
 - b) set the surface and coat it with the primer,
 - c) mark the surface of plasterboard bonding with adhesive,
 - d) bond plasterboards to walls with adhesive
4. Gypsum adhesive for plasterboard bonding should be applied:
 - a) all over the plasterboard,
 - b) in three continuous vertical lines,
 - c) in horizontal lines, 30 cm apart,
 - d) in lines along plasterboard edges and pointwise in the plasterboard area.
5. When a wall is longer than 6 m, fixing plasterboards with adhesive should start from:
 - a) the centre of the wall,
 - b) the angle of the wall.
6. Identify three instances when installation of wall linings on CD60 profiles is justified:
 - a)
 - b)
 - c)
7. CD60 profiles in wall lining systems are positioned:
 - a) horizontally and vertically on plasterboard junctions,
 - b) horizontally, 60 cm apart,
 - c) vertically, 60 cm apart,
 - d) vertically on plasterboard junctions.
8. What profiles are used for the pre-wall assembly?
.....
9. What is the size of overlaps used in the assembly of pre-walls of the following heights:
 - a) 3 m-,
 - b) 4 m-,
 - c) 5 m -

10. While determining the positioning of a wall lining on CD60 profiles, the marking lines are drawn on:
- the walls, the ceiling and the floor,
 - the walls,
 - the floor,
 - the ceiling and the floor.
11. While determining the pre-wall positioning, lines are drawn on:
- the walls, the ceiling and the floor,
 - the walls,
 - one wall and the ceiling,
 - the floor and the ceiling.
12. After determination of the plasterboard positioning, installation of a wall lining starts from fixing:
- CD60 profiles on the wall,
 - UD30 profiles on the floor,
 - ES brackets on the wall.
13. Can CD60 and UD30 profiles be connected permanently?
- yes.
 - no.
14. For the pre-wall assembly, one uses profiles:
- CD, UD,
 - CD, UW,
 - CW, UW,
 - CW, UD.
15. A vapour-insulation foil is used in the case of installing:
- wall linings on CD60 profiles in all walls,
 - all pre-walls,
 - wall linings and pre-walls on the external wall,
 - wall linings and pre-walls on the external wall when mineral wool is applied.
16. Plasterboards are fixed with screws to:
- CD60 profiles,
 - UD30 profiles,
 - both types of profiles - CD60 and UD30,
 - both types of profiles - CD60 and UD30, when the wall is more than 6 m in length.

17. When installing plasterboards in wall lining systems, one must:
- a) place the boards directly on the floor,
 - b) leave a gap of ca. 1 cm from the floor,
 - c) place a board in such a way as to avoid its contact with the floor,
 - d) place it on a UD30 profile.

18. During the first mudding, the “mud” is spread:
- a) along a joint,
 - b) across a joint,

19. Which gypsum mudding quality level is used when ceramic tiles are to be used on a wall lining?

.....,

20. What is the purpose of using a priming coat?

.....,

ANSWER SHEET

Name and surname

Installation of wall lining systems

Mark the correct answer, write in a missing phrase or an answer.

Question number	Answers				Points scored	
1						
2						
3	a	b	c	d		
4	a	b	c	d		
5	a		b			
6						
7	a	b	c	d		
8						
9						
10	a	b	c	d		
11	a	b	c	d		
12	a		b		c	
13	A		b			
14	a	B	c	d		
15	a	b	c	d		
16	a	b	c	d		
17	a	b	c	d		
18	A		b			
19						
20						
Total						

7. BIBLIOGRAPHY

1. Baranowicz W.: Wytyczne w zakresie ochrony przeciwpożarowej oraz wzór instrukcji bezpieczeństwa pożarowego dla obiektów szkół. MEN, Warszawa 1997
2. Specialist magazines of companies specializing in Drywall systems.
3. Jerzak M.: Bezpieczeństwo i higiena pracy w budownictwie. PWN, Warszawa 1980
4. Ketler K.: Murarstwo, cz. 2, REA, Warszawa 2002
5. Labour Code (currently binding)
6. Mac S., Leowski J.: Bezpieczeństwo i Higiena Pracy. Podręcznik dla szkół zasadniczych. WSiP, Warszawa 1999
7. Maj T.: Organizacja Budowy. WSiP, Warszawa 2009
8. Martinek W., Szymański E.: Murarstwo i tynkarstwo. WSiP, Warszawa 1999
9. Popek M., Wapińska B.: Podstawy budownictwa. WSiP, Warszawa 2009
10. Poradnik majstra budowlanego. Praca zbiorowa. Arkady, Warszawa 1997
11. Regulation of the Minister of Building and Building Materials of 28.03.1972 on occupational safety and work hygiene at building, assembly and dismantling works (Journal of Laws, No 13, item. 93)
12. Regulation of the Minister of Labor and Social Policy of 26.09.1997 on general safety and hygiene at work. Journal of Laws no 129, item 844
13. Regulation of the Minister for Internal Affairs of 3.11.1992 concerning fire-protection of buildings and other building structures and areas. Journal of Laws No. 92, item 460; Journal of Laws No 102/95, item 507
14. Regulation of the Council of Ministers of 28.07.1998r. on the definition of the circumstances and reasons for accidents at work and the method of documenting them, as well as the scope of information included in the register of accidents at work . Journal of Laws no 115, item 744
15. Szymański E., Wrześniowski Z.: Materiały budowlane. WSiP, Warszawa 1997
16. Szymański E.: Materiałoznawstwo budowlane. WSiP, Warszawa 1999
17. Wasilewski Z.: BHP na placu budowy. Arkady, Warszawa 1989
18. Wojewoda K.: Magazynowanie, składowanie i transportowanie materiałów budowlanych. Zeszyt 3. Podręcznik dla ucznia. REA, Warszawa 1999
19. Wolski Z.: Roboty podłogowe i okładzinowe, WSiP, Warszawa 1998
20. Zastosowanie płyt kartonowo-gipsowych w budownictwie, materiał instruktażowy dla szkół budowlanych, Polskie Stowarzyszenie Gipsu, Warszawa 2004

Bibliography should be updated as new publications appear on the market.